

SportRack®

4EZ
A30902 • 91140

HITCH PLATFORM SYSTEM
PLATE-FORME POUR ATTELAGE
PLATAFORMA PARA ENGANCHE

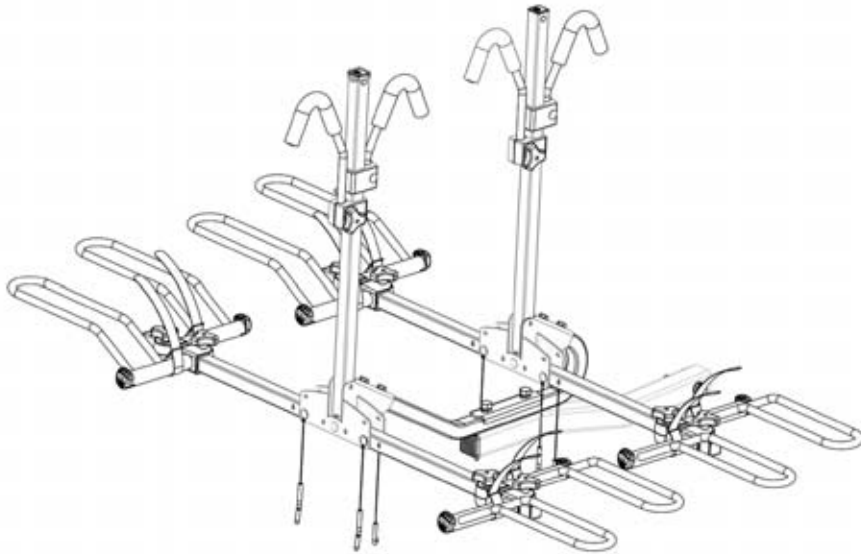

MAX
180 Lb • 80 Kg

A32022 • 91353
A30901LHP • 91351
A32020 • 91352

Optional locking kits available
Ensembles de verrouillage disponibles en option
Kits de seguridad opcionales

NOTE: Hitch must have a minimum Class II rating.

NOTE : Le véhicule doit comporter un dispositif d'attelage minimum de catégorie II.

NOTA: La clasificación mínima del enganche de remolque debe ser Clase II.

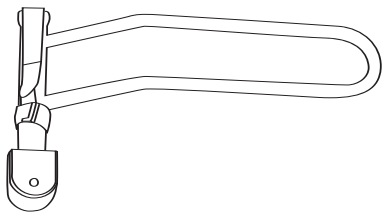

A 4X

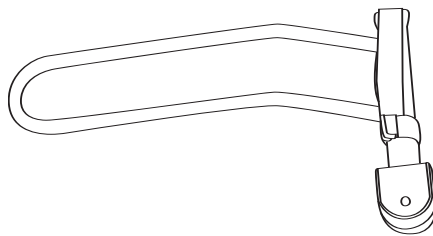

B 4X

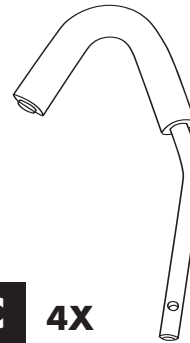

C 4X

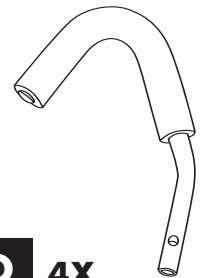

D 4X

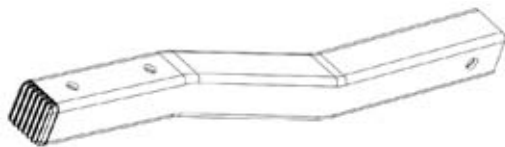

E 1X



F 1X



G 12X

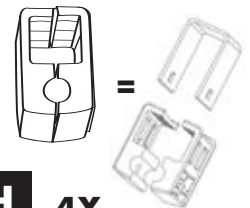

H 4X

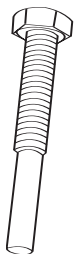

I 1X

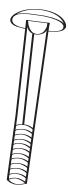

J 12X

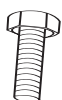

K 4X



L 3X



M 4X



N 1X



O 1X

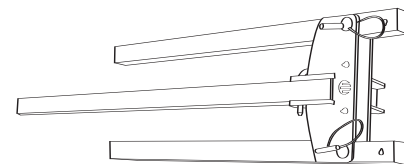

P 2X

Q 1X



R 2X

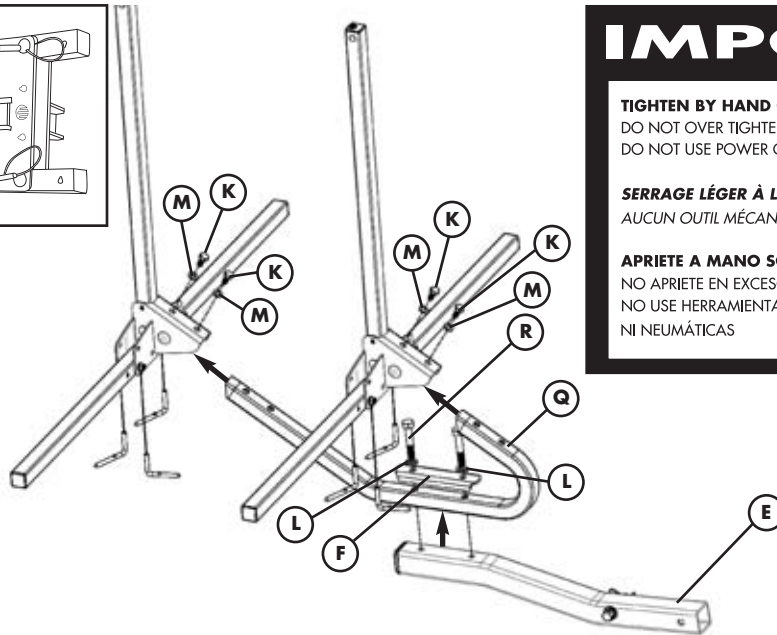
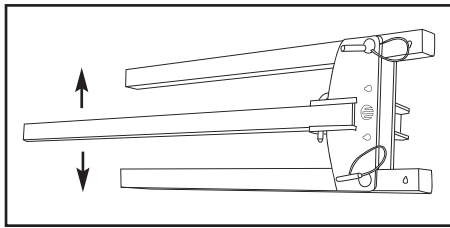

IMPORTANT

TIGHTEN BY HAND ONLY,
DO NOT OVER TIGHTEN
DO NOT USE POWER OR PNEUMATIC TOOLS

SERRAGE LÉGER À LA MAIN SEULEMENT
AUCUN OUTIL MÉCANIQUE OU PNEUMATIQUE

APIRIETE A MANO SOLAMENTE,
NO APRIETE EN EXCESO
NO USE HERRAMIENTAS ELÉCTRICAS
NI NEUMÁTICAS



1

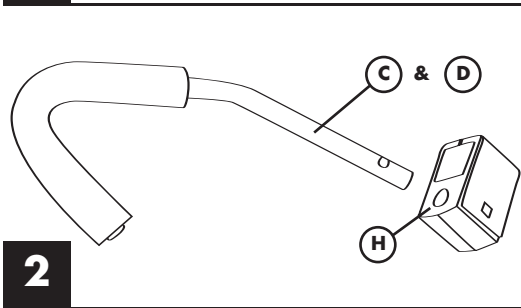

2

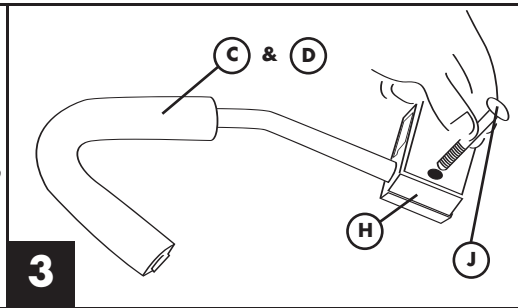

3

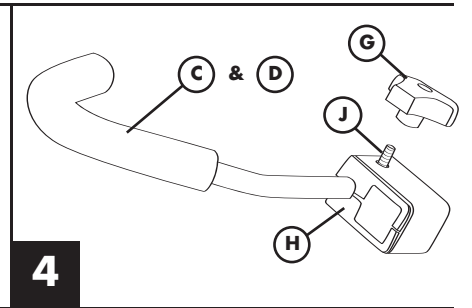

4

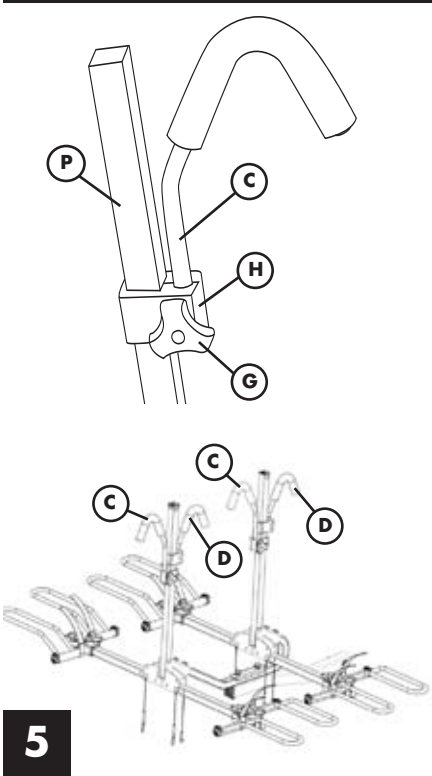

5

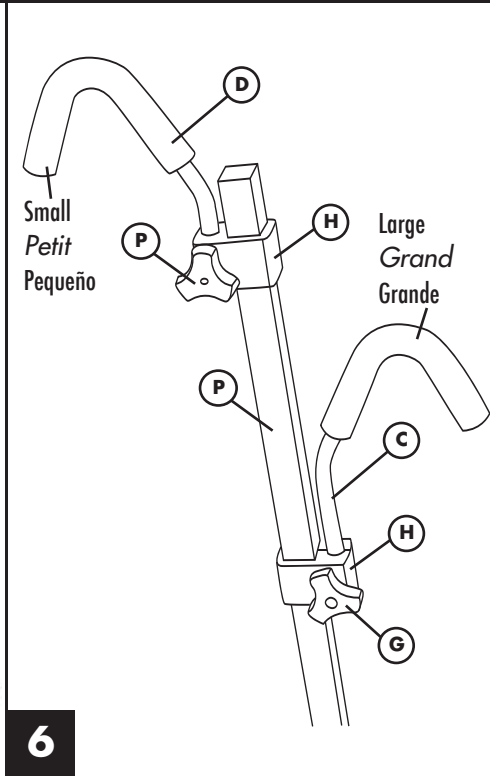

6

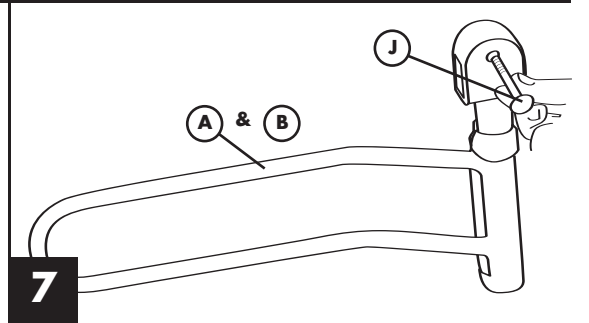

7

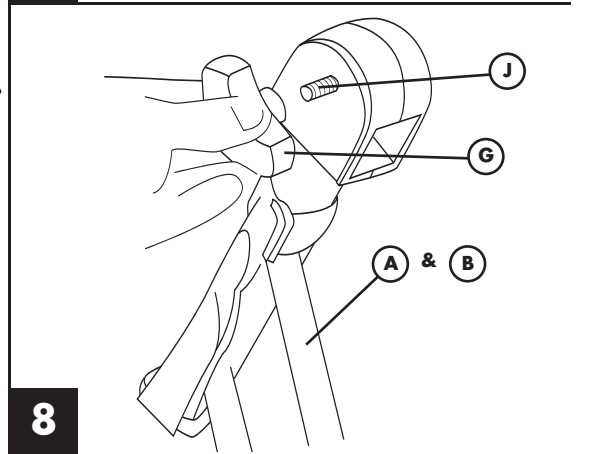

8

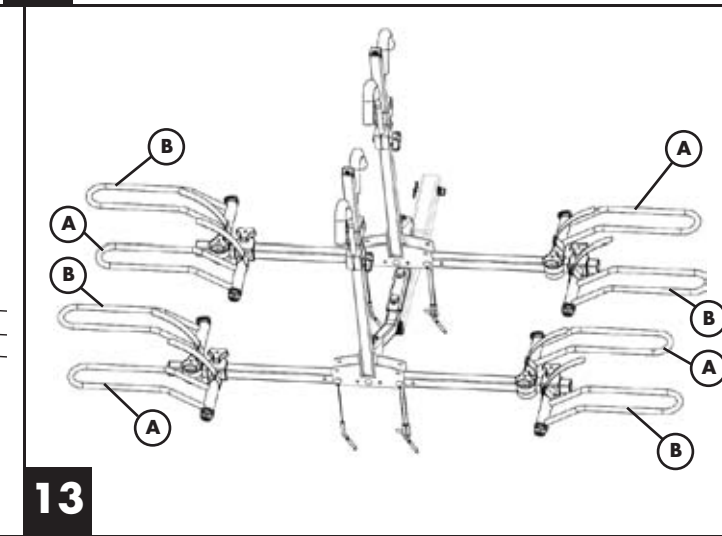
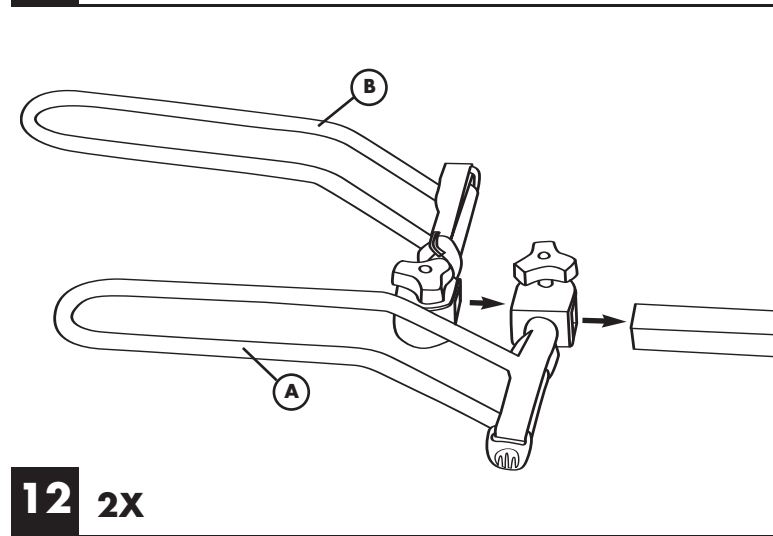
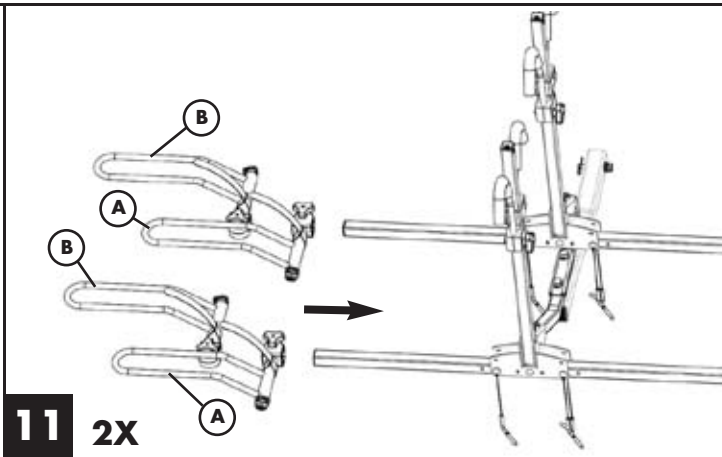
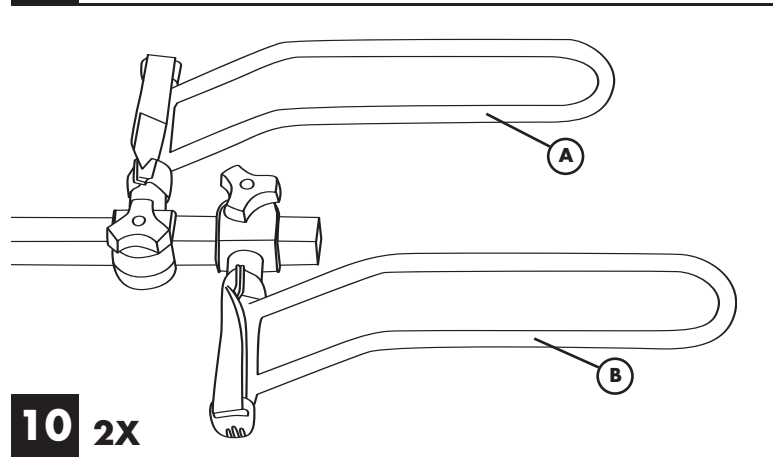
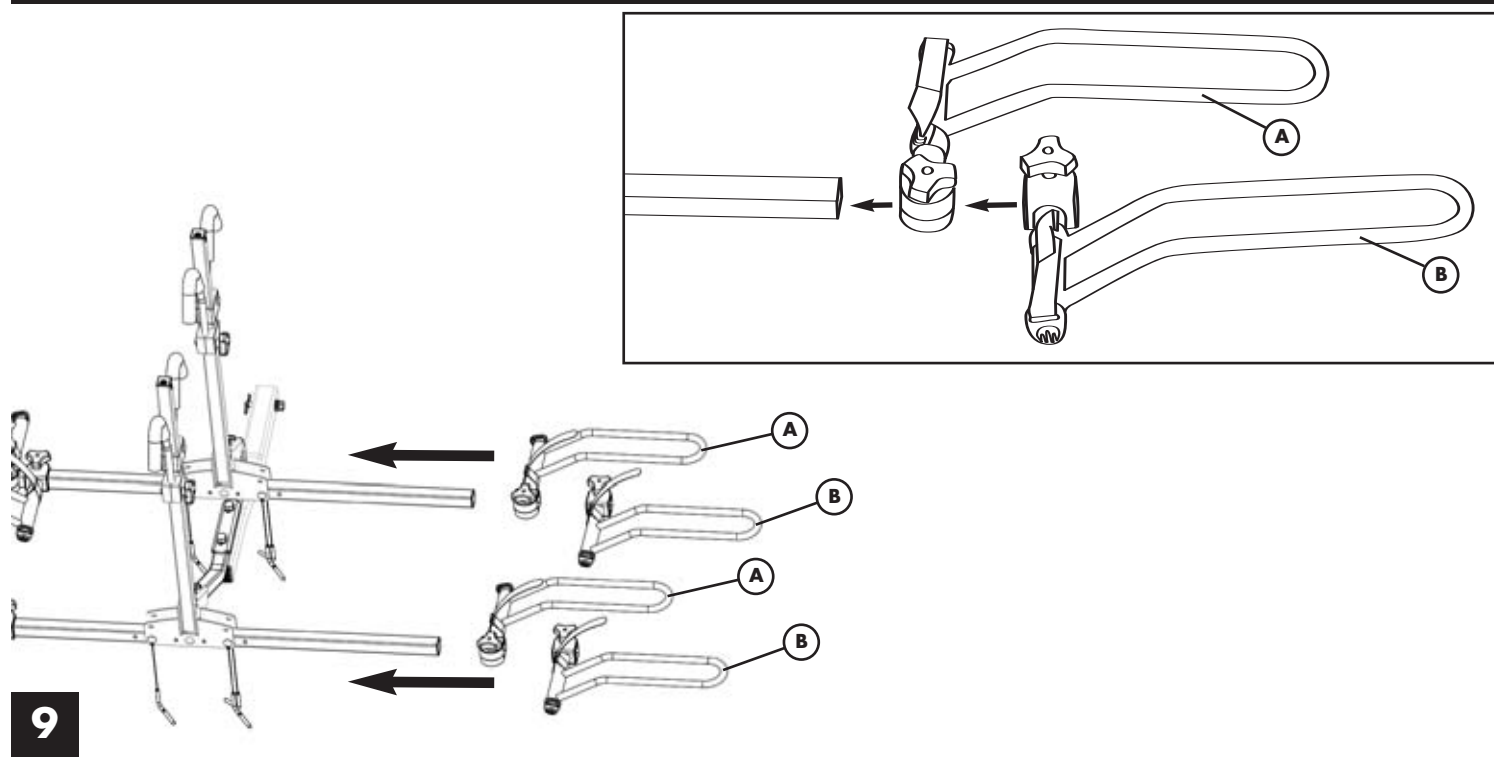

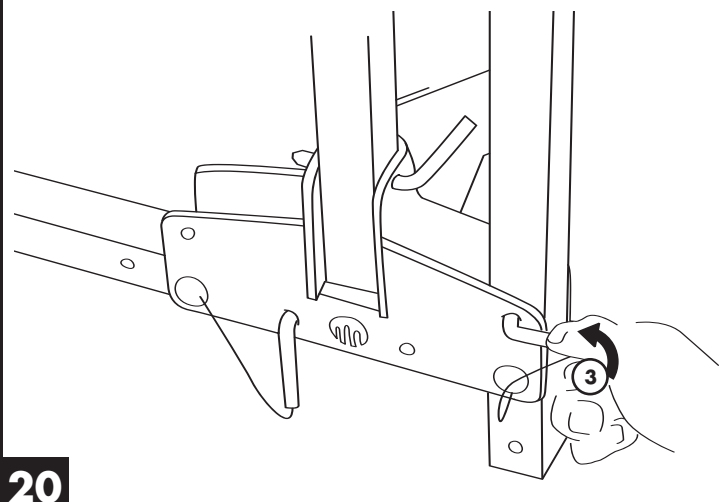
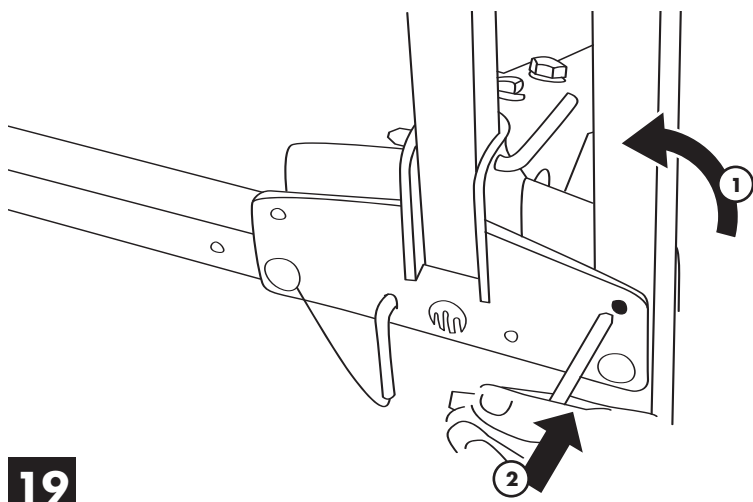
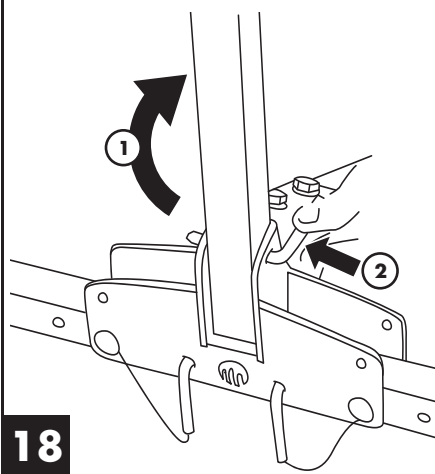
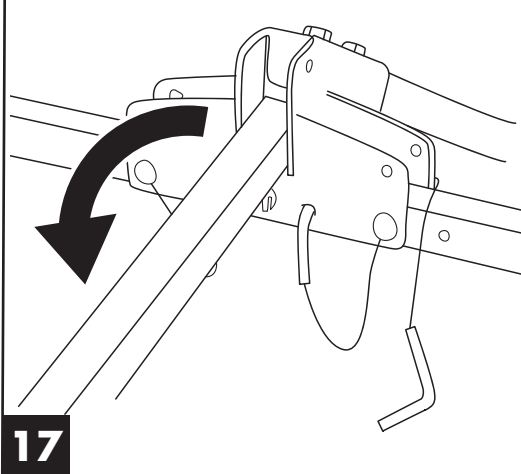
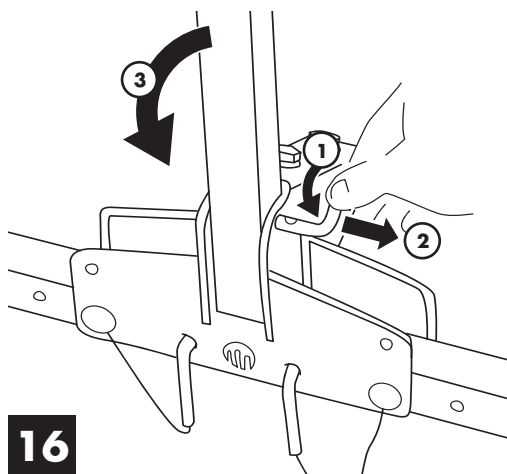
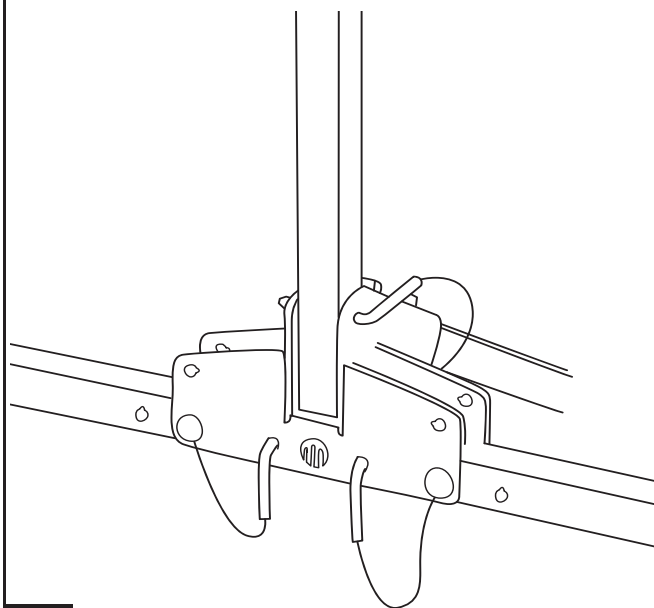
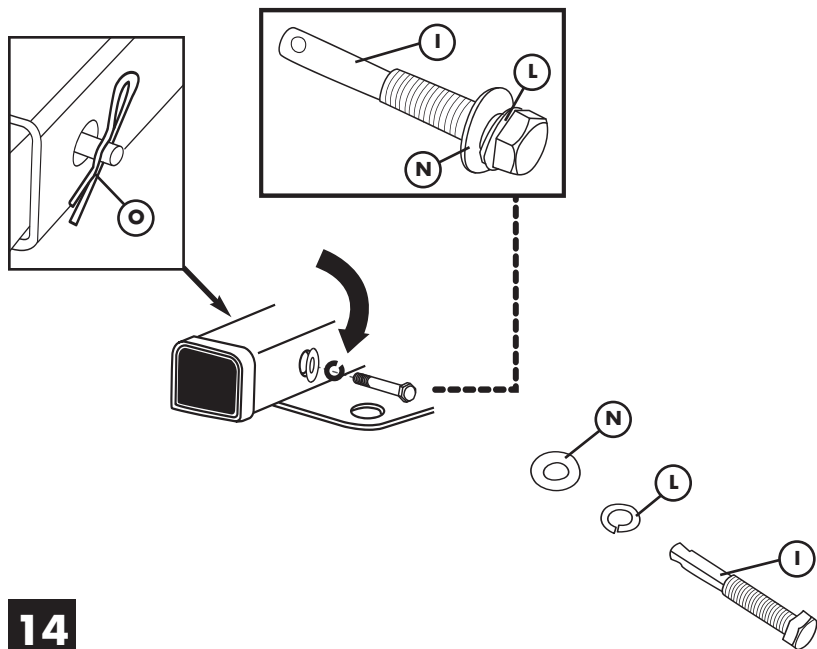

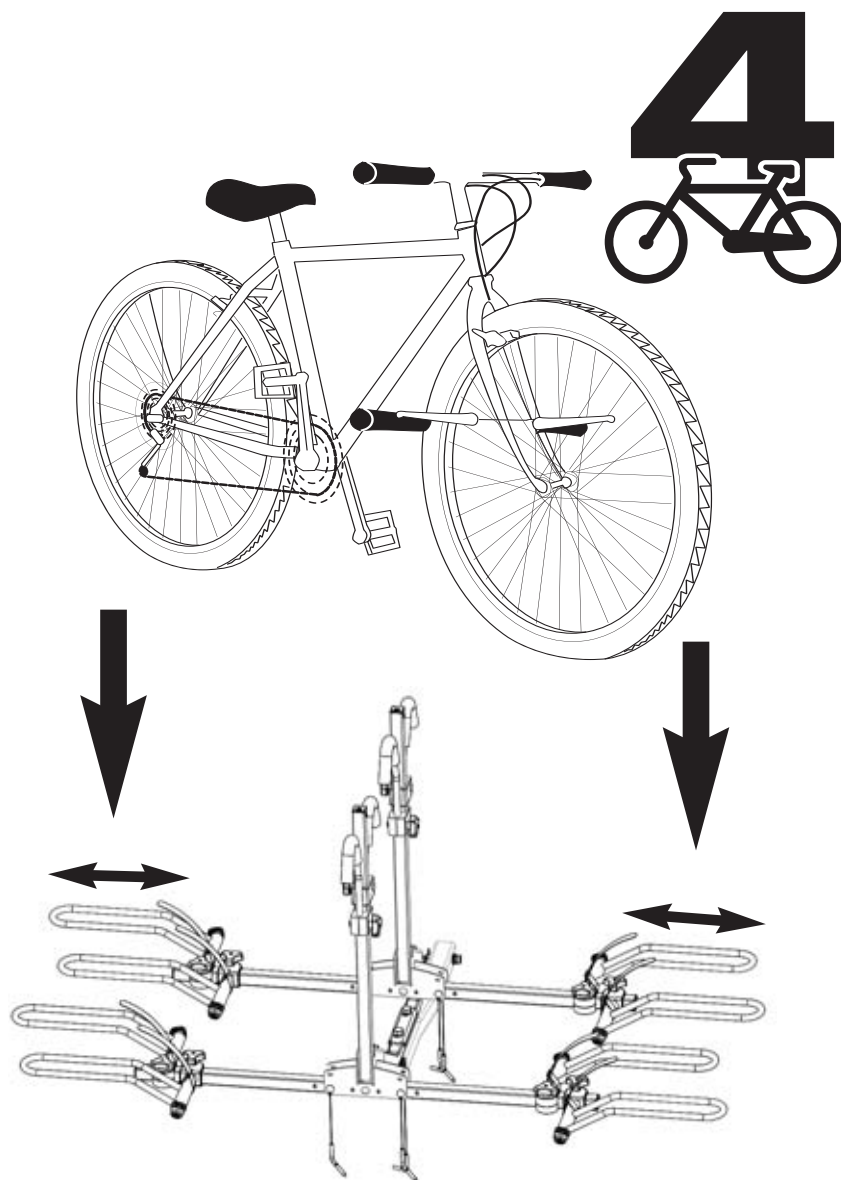

21

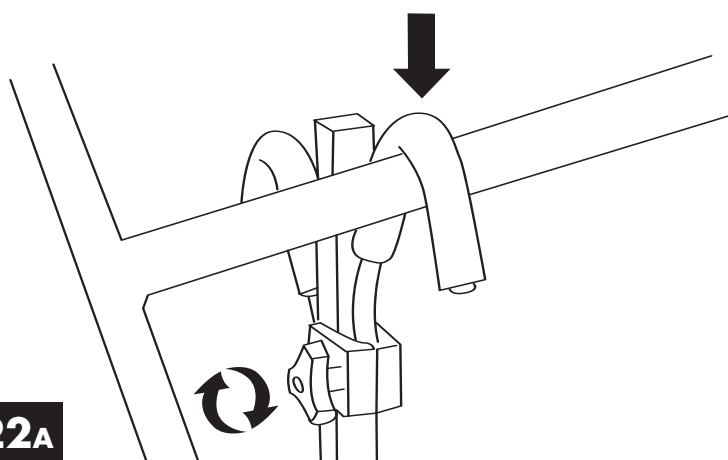

22A

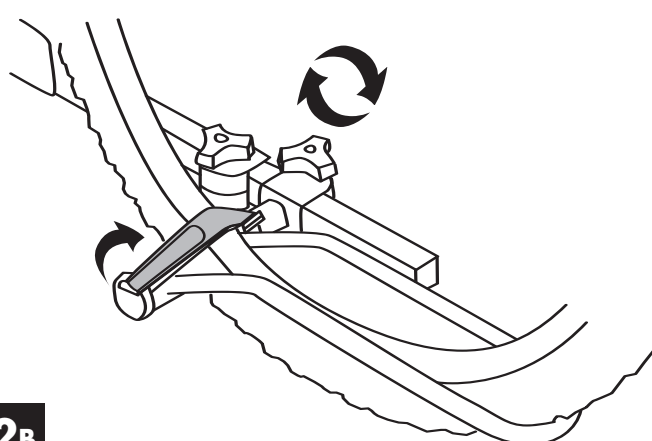

22B

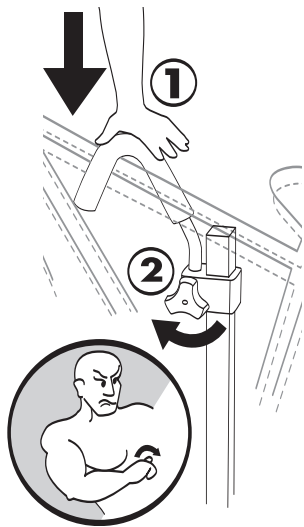

MAKE SURE HOOKS ARE WELL SUPPORTED ON BICYCLES AND TIGHTEN BOTH HANDLES (IF THERE ARE 4 BICYCLES) UNTIL HOOKS ARE COMPLETELY MOTIONLESS.

BIEN APPUYER LES CROCHETS SUR LES VÉLOS ET SERRER LES 4 POIGNÉES (SI 4 VÉLOS) JUSQU'À UNE TOTALE IMMOBILITÉ DES CROCHETS.

APOYAR BIEN LOS GANCHOS SOBRE LAS BICICLETAS Y AJUSTAR LAS 4 MANIJAS (SI HAY 4 BICICLETAS) HASTA LOGRAR LA INMOVILIDAD TOTAL DE LOS GANCHOS.

ENSURE THAT EACH TIRE IS WELL SUPPORTED BY BOTH ENDS OF HOOP.

S'ASSURER QUE CHAQUE PNEU EST BIEN APPUYÉ AUX 2 EXTRÉMITÉS DU CERCEAU.

ASEGURARSE DE QUE CADA RUEDA HAYA QUEDADO CORRECTAMENTE APOYADA SOBRE LAS 2 EXTREMIDADES DEL ARO.

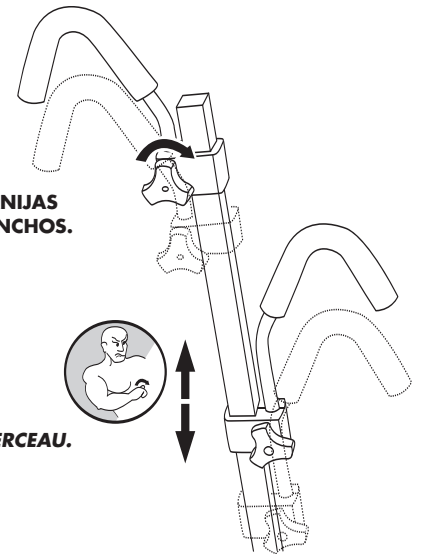

WOMEN'S BICYCLES • VÉLO DE DAME • BICICLETAS DE MUJER VEN

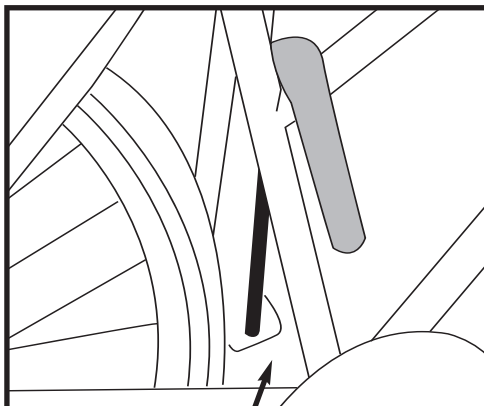

1. ALWAYS POSITION SMALLER BICYCLE BETWEEN THE BICYCLE SUPPORT AND THE CAR BUMPER USING THE LARGE HOOK.

1. TOUJOURS POSITIONNER LE PLUS PETIT VÉLO ENTRE LE SUPPORT À VÉLO ET LE PARE-CHOC DE LA VOITURE À L'AIDE DU GRAND CROCHET.

1. COLOCAR SIEMPRE LA BICICLETA MÁS PEQUEÑA ENTRE EL PORTABICICLETAS Y EL PARACHOQUES DEL VEHÍCULO UTILIZANDO EL GANCHO MÁS LARGO.

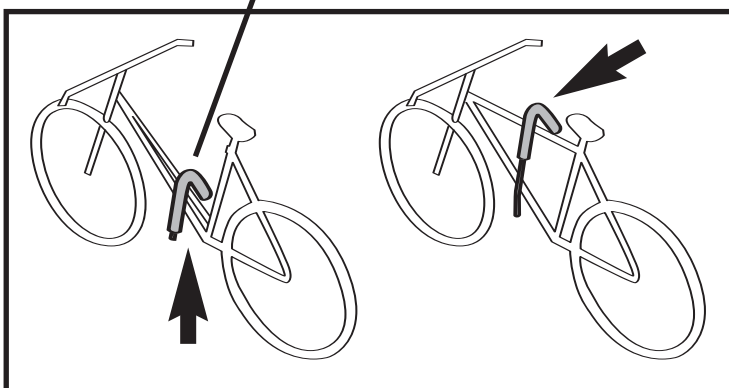

2. FOR BICYCLES WITH INCLINED FRAME (WOMENS' BICYCLES), POSITION HOOK IN THE CAVITY, I.E. BETWEEN THE VERTICAL TUBE AND THE INCLINED TUBE OF BICYCLE. (SEE ILLUSTRATION BELOW)

2. POUR LES VÉLOS À CADRE INCLINÉ (VÉLO DE DAME), POSITIONNER LE CROCHET DANS LE CREUX, C'EST-À-DIRE ENTRE LE TUBE VERTICAL ET LE TUBE INCLINÉ DU VÉLO. (VOIR ILLUSTRATION CI-DESSOUS)

2. PARA LAS BICICLETAS DE CUADRO INCLINADO (BICICLETA DE DAMA), COLOCAR EL GANCHO EN LA CAVIDAD, ES DECIR ENTRE EL CAÑO VERTICAL Y EL CAÑO INCLINADO DE LA BICICLETA. (VER ILUSTRACIÓN MÁS ADELANTE)

3. THE BUYER SHOULD BE AWARE THAT THE COMBINED WEIGHT OF THE BICYCLE CARRIER AND BICYCLES COULD EXCEED THE MAXIMUM WEIGHT ALLOWED FOR A TRAILER OR A FIFTH-WHEEL. NOT RESPECTING THE PERMISSIBLE MAXIMUM LOAD AUTOMATICALLY VOIDS WARRANTY.

3. L'ACHETEUR DOIT SAVOIR QUE LA CHARGE CRÉÉE PAR LE PORTE-BICYCLETTE ET LES VÉLOS POURRAIENT DÉPASSER LA CHARGE MAXIMALE PERMISE POUR UNE REMORQUE OU UNE CINQUIÈME ROUE. LE NON RESPECT DE LA CHARGE MAXIMALE ANNULE LA GARANTIE.

3. EL COMPRADOR DEBE SABER QUE EL PESO COMBINADO DEL PORTABICICLETAS Y LAS BICICLETAS PODRÍA SUPERAR LA CARGA MÁXIMA PERMITIDA PARA UN REMOLQUE O PARA UNA QUINTA RUEDA. EL INCUMPLIMIENTO DE LAS DISPOSICIONES RELATIVAS A LA CARGA MÁXIMA ANULA LA GARANTÍA.

SportRack®

700 Bernard, Granby, Qc Canada J2G 9H7

1-800-561-0716 • www.sportrack.com

LIMITED WARRANTY

All SportRack products carry a one-year limited warranty from the original date of purchase against defects in workmanship or materials. If any defect appears in SportRack product during warranty, the SportRack product must be returned shipping paid to the manufacturer or distributor. Repaired or replaced products will be shipped by the manufacturer or distributor. Request must be by letter bearing your name and address and explaining the problem and be accompanied by proof of purchase.

EXCLUSIONS TO WARRANTY

This warranty will not apply if the product has been modified, damaged or misused.

Any and all implicit warranties, including any implied warranty of merchantability of fitness for a particular purpose, shall not exceed in duration the term of limited warranty. In no event shall the manufacturer or the distributor be liable for tortious or indirect damages.

DRIVE SAFE. THE HANDLING CHARACTERISTICS OF YOUR VEHICLE WILL BE AFFECTED WHEN CARRYING LOADS (CORNERING, BRAKING, CROSS WINDS, ETC...)

GARANTIE LIMITÉE

Tous les produits SPORTRACK comportent une garantie limitée d'un an, à partir de la date d'achat initial, contre les défauts de matériau et de fabrication. Si au cours de la période de garantie, le produit SPORTRACK présente une quelconque défectuosité, il doit être retourné au fabricant ou au distributeur, frais de port payés. Celui-ci se chargera de payer le port de retour de l'article peu importe qu'il soit réparé ou remplacé. Pour ce faire, vous devez joindre une lettre portant votre nom et adresse expliquant le problème, accompagnée de la preuve d'achat.

EXCLUSIONS

Cette garantie n'est pas valide si le produit a été modifié, endommagé ou mal utilisé. Toutes les garanties implicites, y compris toute garantie implicite liée à la qualité marchande ou à l'adaptation à un usage particulier, n'excéderont pas la période de cette garantie limitée.

En aucun cas, le fabricant ou le détaillant ne seront tenus responsables des dommages tortueux ou indirects.

CONDUISEZ PRUDEMMENT, LA TENUE DE ROUTE DE VOTRE VÉHICULE PEUT ÊTRE AFFECTÉE QUAND VOUS TRANSPORTEZ UNE CHARGE (EN CAS DE VIRAGES, FREINAGE, VENTS LATÉRAUX, ETC.)

GARANTÍA LIMITADA

Todos los productos SPORTRACK tienen una garantía limitada de un año, a partir de la fecha de compra original, que cubre cualquier defecto de fabricación o de material. Si necesita utilizar el servicio de garantía, envíe el producto SportRack y la factura con franqueo pagado dentro del período de garantía al fabricante o al distribuidor. Éste se hará cargo del envío de los productos reparados o reemplazados. Adjunte una carta indicando su nombre, dirección y el defecto del producto.

EXCLUSIONS

Esta garantía no tendrá validez cuando el producto haya sido modificado, dañado o se haya utilizado inadecuadamente. Cualquier otra garantía aplicable, incluso una garantía implícita de aptitud para la comercialización no excederá la vigencia de la garantía limitada. El fabricante y el distribuidor no serán responsables por los daños directos o indirectos.

CONDUZCA CON PRUDENCIA. CUANDO TRANSPORTA CARGAS, LAS CARACTERÍSTICAS DE MARCHA VARIARÁN (AL DOBLAR, FRENAR, EN PRESENCIA DE VIENTOS LATERALES, ETC.)